

SPEED PUNCH® KNOCKOUTS



SAVE TIME AND MONEY WITH EVERY PUNCH!

From the leaders in knockout technology comes the new SPEED PUNCH® System. The patent pending “no-thread” design eliminates cross-threading, while the innovative SPEED LOCK mechanism quickly secures the punch in place. This means longer tool life and faster punches, saving you time and money on the job. SPEED PUNCH® is available in 1/2” - 4” conduit sizes and three kit configurations.



A PRODUCT VIDEO IS AVAILABLE, SCAN THIS QR CODE OR VISIT:
www.youtube.com/GreenleeDEMO

* Compared to standard threaded punch & draw stud set-up and disassembly.



SPECIFICATIONS

Capacity	Mild steel up through 10 gauge (3.5 mm)
Application	Mild steel, fiberglass and plastic enclosures
Hole Sizes	Conduit Sizes - Hole size is outside diameter of US conduit sizes. Example: 3/4" conduit size actually makes a 1-3/32" hole Pg Sizes - European standard pipe sizes ISO Sizes - International Standards Organization pipe sizes
Operation	Operate with manual-hydraulic and battery-hydraulic drivers

STANDARD DRAW STUD END
Works with existing hydraulic and battery-operated punch drivers

RUGGED GROOVES
Holds up on the job – no more damaged threads

NO THREAD PUNCH
Easily slides on/off draw stud

SPEED LOCK
Quickly secures the system in place – more holes, less time.

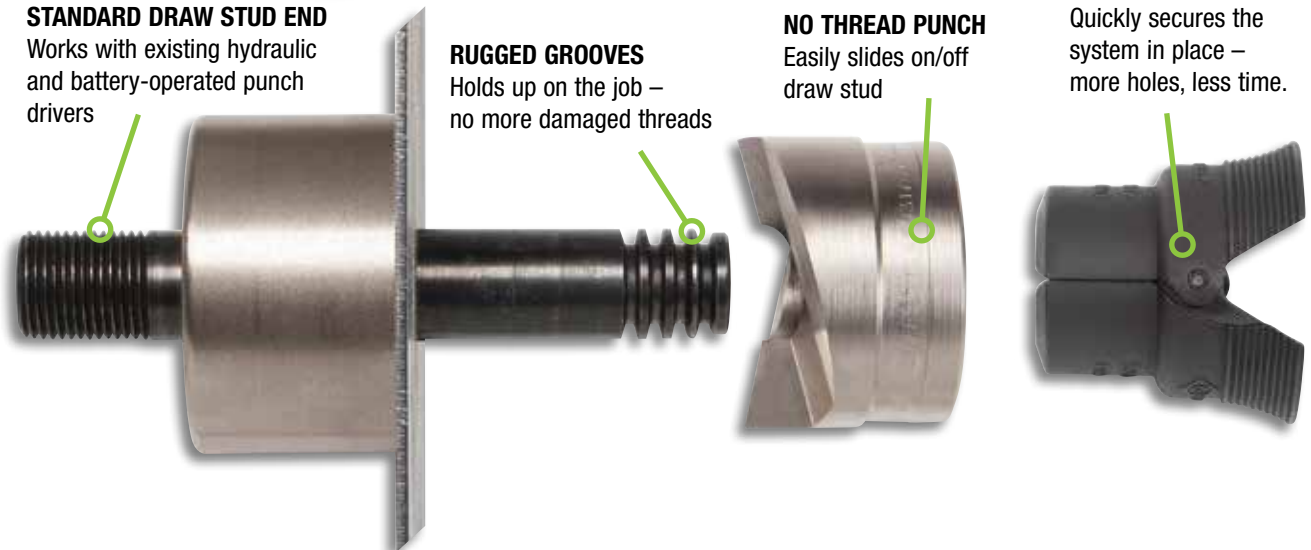

It's as simple as:

“No-thread” punch design quickly and easily slides on/off draw stud: The fastest punch system on the market today.



1 SLIDE
Slide die and punch onto draw stud: “No-thread” design eliminates cross-threading.



2 SECURE
Secure SPEED LOCK onto draw stud: Faster setup and disassembly.



3 PUNCH
Punch hole: Save time and money with every punch!

Mild Steel SPEED PUNCH® Knockout System



See below for kit contents

- Available in 1/2" to 4" conduit sizes
- Punch up to 10 gauge (3.5 mm) mild steel, aluminum, fiberglass, and plastic
- Use with hydraulic and battery-powered drivers
- Knockouts Made in the USA



Stainless Steel SPEED PUNCH® Knockout System



See page 68 for kit contents

- Available in 1/2" to 2" conduit sizes
- Punch up to 10 gauge (3.5 mm) stainless and mild steel
- Use with hydraulic and battery-powered drivers
- Knockouts Made in the USA



Oiltight SPEED PUNCH® Knockout System



See page 69 for kit contents

- Available in 22mm & 30mm notched hole sizes
- Punch up to 12 gauge (2.5 mm) mild steel, aluminum, fiberglass, and plastic
- Use with hydraulic and battery-powered drivers
- Knockouts Made in the USA



Metric ISO-16 to ISO-63 SPEED PUNCH® Knockout System



See page 69 for kit contents

- Available in 22mm & 30mm notched hole sizes
- Punch up to 12 gauge (2.5 mm) mild steel, aluminum, fiberglass and plastic
- Use with hydraulic and battery-powered drivers
- Knockouts Made in the USA



SPEED PUNCH® Knockout Kits for Mild Steel

NEW PRODUCT



LS100L11SB4SP

- Available in 1/2" to 4" conduit sizes
- Punch up to 10 gauge (3.5mm) mild steel
- Use with manual-hydraulic and battery-hydraulic knockout drivers
- Knockouts Made in the USA



CAT. NO.	UPC NO.	DESCRIPTION
N LS100L11SB4SP	03143	LS100/SPEED PUNCH® Kit, Mild Steel, 1/2" to 4"
N LS100L11SBSP	03384	LS100/SPEED PUNCH® Kit, Mild Steel, 1/2" to 2"
LS50L11SBSP	02257	LS50/SPEED PUNCH® Kit, Mild Steel, 1/2" to 2"
7310SBSP	01716	Hydraulic SPEED PUNCH® Kit, Mild Steel, 1/2" to 4"
7304SP	01715	SPEED PUNCH® Set, Mild Steel, 2-1/2" to 4"
7908SBSP	02258	Quick Draw SPEED PUNCH® Kit, Mild Steel, 1/2" to 2"
7907SBSP	02259	SPEED PUNCH® Set, Mild Steel, 1/2" to 2"

SPEED PUNCH® Knockout Kits with Battery-Hydraulic Driver for Mild Steel - Parts List

CAT. NO.	UPC NO.	DESCRIPTION	CONDUIT & PIPE SIZE	HOLE SIZE		LS100L11SB4SP	LS100L11SBSP	LS50L11SBSP
				ACTUAL				
				Ø INCH	Ø MM			
7212SP-1/2P	01652	Punch, 1/2", SPEED PUNCH	1/2"	0.885	22.5	✓	✓	✓
7212SP-1/2D	01653	Die, 1/2", SPEED PUNCH				✓	✓	✓
7212SP-3/4P	00952	Punch, 3/4", SPEED PUNCH	3/4"	1.1155	28.3	✓	✓	✓
7212SP-3/4D	09279	Die, 3/4", SPEED PUNCH				✓	✓	✓
7212SP-1-7/32P	01658	Punch, 1-7/32", SPEED PUNCH	-	1.2105	30.5			
7212SP-1-7/32D	01660	Die, 1-7/32", SPEED PUNCH						
7212SP-1P	00953	Punch, 1", SPEED PUNCH	1"	1.3625	34.6	✓	✓	✓
7212SP-1D	09280	Die, 1", SPEED PUNCH				✓	✓	✓
7212SP-1-1/4P	00955	Punch, 1-1/4", SPEED PUNCH	1-1/4"	1.7015	43.2	✓	✓	✓
7212SP-1-1/4D	09281	Die, 1-1/4", SPEED PUNCH				✓	✓	✓
7212SP-1-1/2P	09282	Punch, 1-1/2", SPEED PUNCH	1-1/2"	1.9515	49.6	✓	✓	✓
7212SP-1-1/2D	00956	Die, 1-1/2", SPEED PUNCH				✓	✓	✓
7212SP-2P	09283	Punch, 2", SPEED PUNCH	2"	2.4165	61.5	✓	✓	✓
7212SP-2D	00957	Die, 2", SPEED PUNCH				✓	✓	✓
7212SP-2-1/2P	01629	Punch, 2-1/2", SPEED PUNCH	2-1/2"	2.9145	74.0	✓		
7212SP-2-1/2D	01642	Die, 2-1/2", SPEED PUNCH				✓		
7212SP-3P	01644	Punch, 3", SPEED PUNCH	3"	3.5395	89.9	✓		
7212SP-3D	01645	Die, 3", SPEED PUNCH				✓		
7212SP-3-1/2P	01646	Punch, 3-1/2", SPEED PUNCH	3-1/2"	4.0115	102.7	✓		
7212SP-3-1/2D	01647	Die, 3-1/2", SPEED PUNCH				✓		
7212SP-4P	01650	Punch, 4", SPEED PUNCH	4"	4.5445	115.4	✓		
7212SP-4D	01651	Die, 4", SPEED PUNCH				✓		
7212SP11	10002	Draw Stud, SPEED PUNCH 3/4" x 4.77"						✓
7212SP12	00979	Draw Stud, SPEED PUNCH 3/4" x 5.64"				✓	✓	
7212SP13	01654	Draw Stud, SPEED PUNCH 3/8" x 4.70"				✓	✓	
7212SP14	01655	Draw Stud, SPEED PUNCH 3/8" x 3.83"						✓
SP-LOCK	09277	Speed Lock, 3/4"				✓	✓	✓
SP-LOCK2	01657	Speed Lock, 3/8"				✓	✓	✓
7212AA1	03374	Sleeve Adapter, 746						
7212AA2	03367	Sleeve Adapter, LS Tools				2		
34403	34403	Step Bit, 7/8"				✓	✓	✓
LS100LB	LS100LB	LS100 tool only (includes case)				✓	✓	
LS50LB	LS50LB	LS50 tool only (includes case)						✓
746	17091	Hydraulic Ram						
06302	06302	High Pressure Hose - 1/4" x 3'						
767	17091	Hydraulic Hand Pump						
33786	33786	QuickDraw Driver, Right Angle						
52176	52176	18V 3.0Ah Li-ion Battery				2	2	
52177	52177	18V 1.5Ah Li-ion Battery						2
52177	52177	120V Charger				✓	✓	✓
KK100LFLEX		Case for LS100 kits				✓	✓	
KK50LFLEX		Case for LS50 kits						✓

For more details on Greenlee's new LS100 and LS50 Knockout Drivers and Kits please refer to page 65

SPEED PUNCH® Knockout Kits with Manual-Hydraulic Driver for Mild Steel - Parts List

CAT. NO.	UPC NO.	DESCRIPTION	CONDUIT & PIPE SIZE	HOLE SIZE		7310SBSP	7304SP	7908SBSP
				ACTUAL				
				Ø INCH	Ø MM			
7212SP-1/2P	01652	Punch, 1/2", SPEED PUNCH	1/2"	0.885	22.5	✓		✓
7212SP-1/2D	01653	Die, 1/2", SPEED PUNCH				✓		✓
7212SP-3/4P	00952	Punch, 3/4", SPEED PUNCH	3/4"	1.1155	28.3	✓		✓
7212SP-3/4D	09279	Die, 3/4", SPEED PUNCH				✓		✓
7212SP-1-7/32P	01658	Punch, 1-7/32", SPEED PUNCH	-	1.2105	30.5			
7212SP-1-7/32D	01660	Die, 1-7/32", SPEED PUNCH						
7212SP-1P	00953	Punch, 1", SPEED PUNCH	1"	1.3625	34.6	✓		✓
7212SP-1D	09280	Die, 1", SPEED PUNCH				✓		✓
7212SP-1-1/4P	00955	Punch, 1-1/4", SPEED PUNCH	1-1/4"	1.7015	43.2	✓		✓
7212SP-1-1/4D	09281	Die, 1-1/4", SPEED PUNCH				✓		✓
7212SP-1-1/2P	09282	Punch, 1-1/2", SPEED PUNCH	1-1/2"	1.9515	49.6	✓		✓
7212SP-1-1/2D	00956	Die, 1-1/2", SPEED PUNCH				✓		✓
7212SP-2P	09283	Punch, 2", SPEED PUNCH	2"	2.4165	61.5	✓		✓
7212SP-2D	00957	Die, 2", SPEED PUNCH				✓		✓
7212SP-2-1/2P	01629	Punch, 2-1/2", SPEED PUNCH	2-1/2"	2.9145	74.0	✓	✓	
7212SP-2-1/2D	01642	Die, 2-1/2", SPEED PUNCH				✓	✓	
7212SP-3P	01644	Punch, 3", SPEED PUNCH	3"	3.5395	89.9	✓	✓	
7212SP-3D	01645	Die, 3", SPEED PUNCH				✓	✓	
7212SP-3-1/2P	01646	Punch, 3-1/2", SPEED PUNCH	3-1/2"	4.0115	102.7	✓	✓	
7212SP-3-1/2D	01647	Die, 3-1/2", SPEED PUNCH				✓	✓	
7212SP-4P	01650	Punch, 4", SPEED PUNCH	4"	4.5445	115.4	✓	✓	
7212SP-4D	01651	Die, 4", SPEED PUNCH				✓	✓	
7212SP11	10002	Draw Stud, SPEED PUNCH 3/4" x 4.77"					✓	✓
7212SP12	00979	Draw Stud, SPEED PUNCH 3/4" x 5.64"				✓	✓	
7212SP13	01654	Draw Stud, SPEED PUNCH 3/8" x 4.70"				✓		
7212SP14	01655	Draw Stud, SPEED PUNCH 3/8" x 3.83"						✓
SP-LOCK	09277	Speed Lock, 3/4"				✓	✓	✓
SP-LOCK2	01657	Speed Lock, 3/8"				✓		✓
7212AA1	03374	Sleeve Adapter, 746				2	2	
7212AA2	03367	Sleeve Adapter, LS Tools					2	
34403	34403	Step Bit, 7/8"				✓		✓
746	17091	Hydraulic Ram				✓		
06302	06302	High Pressure Hose - 1/4" x 3'				✓		
767	13284	Hydraulic Hand Pump				✓		
33786	33786	QuickDraw Driver, Right Angle						✓
05387	05387	Case for 7310 Sets				✓		
02868	02868	Case for 7908SBSP						✓

For more details on Greenlee's new LS100 and LS50 Knockout Drivers and Kits please refer to page 65

SPEED PUNCH® Knockout Kit for Stainless Steel

**NEW
PRODUCT**



LS100L1SSSP

- Available in 1/2" to 2" conduit sizes
- Punch up to 10 gauge (3.5mm) stainless and mild steel
- Use with manual-hydraulic and battery-hydraulic knockout drivers
- Knockouts Made in the USA



CAT. NO.	UPC NO.	DESCRIPTION
N LS100L1SSSP	03148	LS100/SPEED PUNCH Kit, Stainless Steel, 1/2" - 2"
7307SP	01720	SPEED PUNCH Set, Stainless Steel, 1/2" - 2"



7307SP

SPEED PUNCH® Knockout Kits for Stainless Steel - Parts List

CAT. NO	UPC NO.	DESCRIPTION	CONDUIT & PIPE SIZE	HOLE SIZE		LS100L1SSSP	7307SP
				ACTUAL			
				Ø INCH	Ø MM		
745SP-1/2P	01661	SPEED PUNCH Punch, SS, 1/2"	1/2"	0.885	22.5	✓	✓
745SP-1/2D	01662	SPEED PUNCH Die, SS, 1/2"				✓	✓
745SP-3/4P	01663	SPEED PUNCH Punch, SS, 3/4"	3/4"	1.115	28.3	✓	✓
745SP-3/4D	01665	SPEED PUNCH Die, SS, 3/4"				✓	✓
745SP-1-7/32P	01667	SPEED PUNCH Punch, SS, 1-7/32"	-	1.210	30.5	✓	✓
745SP-1-7/32D	01668	SPEED PUNCH Die, SS, 1-7/32"				✓	✓
745SP-1P	01669	SPEED PUNCH Punch, SS, 1"	1"	1.362	34.6	✓	✓
745SP-1D	01670	SPEED PUNCH Die, SS, 1"				✓	✓
745SP-1-1/4P	01671	SPEED PUNCH Punch, SS, 1-1/4"	1-1/4"	1.701	43.2	✓	✓
745SP-1-1/4D	01672	SPEED PUNCH Die, SS, 1-1/4"				✓	✓
745SP-1-1/2P	02531	SPEED PUNCH Punch, SS, 1-1/2"	1-1/2"	1.951	49.6	✓	✓
745SP-1-1/2D	01678	SPEED PUNCH Die, SS, 1-1/2"				✓	✓
745SP-2P	01679	SPEED PUNCH Punch, SS, 2"	2"	2.416	61.5	✓	✓
745SP-2D	01681	SPEED PUNCH Die, SS, 2"				✓	✓
7212SP21	01682	Draw Stud, SPEED PUNCH 3/4" x 5.84"				✓	
7212SP22	01683	Draw Stud, SPEED PUNCH 3/8" x 4.70"				✓	
7212SP23	01724	Draw Stud, SPEED PUNCH 3/4" x 5.02"					✓
7212SP24	02276	Draw Stud, SPEED PUNCH 3/8" x 3.83"					✓
SP-LOCK	09277	Speed Lock, 3/4"				✓	✓
SP-LOCK2	01657	Speed Lock, 3/8"				✓	✓
LS100LB	LS100LB	LS100 Tool only (includes case)				✓	
52176	52176	Battery, 18V 3.0Ah Li-Ion				✓	
52178	52178	120V Charger				✓	
KK100LFLEX		Case for LS100 Kits				✓	

For more details on Greenlee's new LS100 and LS50 Knockout Drivers and Kits please refer to page 65

SPEED PUNCH® Knockout Set - Oiltight Punches with Notches



- Pushbutton knockouts
- Available in 22.5mm & 30.5mm notched hole sizes
- Punch up to 12 gauge (2.5mm) mild steel, aluminum, fiberglass and plastic
- Use with manual-hydraulic and battery-hydraulic knockout drivers
- Oiltight SPEED PUNCH® units include punch, die, draw stud and speed lock

CAT. NO.	UPC NO.	DESCRIPTION
7212SP-PB22U	02260	Oiltight Punch Unit, 22.5mm, SPEED PUNCH
7212SP-PB30U	02263	Oiltight Punch Unit, 30.5mm, SPEED PUNCH

KEY	CAT. NO.	UPC NO.	DESCRIPTION	7212SP-PB22U	7212SP-PB30U
A	7212SP-PB22P	01705	Oiltight Punch, 22.5mm, SPEED PUNCH	✓	
B	7212SP-PB22D	60250	Oiltight Die, 22.5mm, SPEED PUNCH	✓	
C	7212SP-PB30P	01709	Oiltight Punch, 30.5mm, SPEED PUNCH		✓
D	7212SP-PB30D	60249	Oiltight Die, 30.5mm, SPEED PUNCH		✓
-	7212SP31	01712	Oiltight Draw Stud for LS100 or 746 driver		
-	7212SP32	02261	Oiltight Draw Stud for LS50 or Quick Draw driver	✓	✓
E	SP-LOCK2	01657	Speed Lock Assembly (3/8)	✓	✓

SPEED PUNCH® Knockout Set - METRIC



- Pushbutton knockouts
- Available in 22.5mm & 30.5mm notched hole sizes
- Punch up to 12 gauge (2.5mm) mild steel, aluminum, fiberglass and plastic
- Use with manual-hydraulic and battery-hydraulic knockout drivers
- Oiltight SPEED PUNCH® units include punch, die, draw stud and speed lock

CAT. NO.	UPC NO.	DESCRIPTION
7217SBS	01723	SPEED PUNCH® Set, Metric, ISO-16 to ISO-40

CAT. NO.	UPC NO.	DESCRIPTION	7217SBS
7212SP-M16P	01684	Punch, ISO-16, SPEED PUNCH	✓
7212SP-M16D	01685	Die, ISO-16, SPEED PUNCH	✓
7212SP-M20P	01687	Punch, ISO-20, SPEED PUNCH	✓
7212SP-M20D	01688	Die, ISO-20, SPEED PUNCH	✓
7212SP-M25P	01689	Punch, ISO-25, SPEED PUNCH	✓
7212SP-M25D	01690	Die, ISO-25, SPEED PUNCH	✓
7212SP-M32P	01691	Punch, ISO-32, SPEED PUNCH	✓
7212SP-M32D	01692	Die, ISO-32, SPEED PUNCH	✓
7212SP-M40P	01693	Punch, ISO-40, SPEED PUNCH	✓
7212SP-M40D	01694	Die, ISO-40, SPEED PUNCH	✓
7212SP-M50P	01697	Punch, ISO-50, SPEED PUNCH	
7212SP-M50D	01701	Die, ISO-50, SPEED PUNCH	
7212SP-M63P	01703	Punch, ISO-63, SPEED PUNCH	
7212SP-M63D	01704	Die, ISO-63, SPEED PUNCH	
7212SP11	10002	Draw Stud, SPEED PUNCH 3/4" x 4.77"	✓
7212SP14	01655	Draw Stud, SPEED PUNCH 3/8" x 3.83"	✓
SP-LOCK	09277	Speed Lock, 3/4"	✓
SP-LOCK2	01657	Speed Lock, 3/8"	✓