

RMP85

miniature relays

RMP85 (AC)



RMP85 (DC)



- Cadmium - free contacts • Height 25,5 mm
- Reinforced insulation
- For plug-in sockets
- Accessories: sockets and modules
- AC and DC coils
- WT (mechanical indicator + lockable front test button)
- standard equipment of relays
- Recognitions, certifications, directives: RoHS,

Contact data

Number and type of contacts		1 CO
Contact material		AgNi
Rated / max. switching voltage	AC	250 V / 440 V
Min. switching voltage		12 V 10 mA
Rated load	AC1	16 A / 250 V AC
Min. switching current		10 mA 12 V
Max. inrush current		32 A 20 ms
Rated current		16 A
Max. breaking capacity	AC1	4 000 VA
Min. breaking capacity		0,12 W 10 mA / 12 V
Contact resistance		≤ 100 mΩ 1 A / 6 V DC
Max. operating frequency		
• at rated load	AC1	360 cycles/hour
• no load		18 000 cycles/hour

Coil data

Rated voltage	50 Hz AC	24, 115, 230 V
	DC	12, 24, 48, 110 V
Must release voltage		AC: ≥ 0,15 U _n DC: ≥ 0,1 U _n
Operating range of supply voltage		see Tables 1, 2
Rated power consumption	AC	0,75 VA
	DC	0,4 ... 0,48 W

Insulation according to EN 60664-1

Insulation rated voltage		440 V AC
Rated surge voltage		4 000 V 1,2 / 50 μs
Overvoltage category		III
Insulation pollution degree		3
Insulation resistance		1 000 MΩ 500 V DC
Dielectric strength		
• between coil and contacts		5 000 V AC type of insulation: reinforced
• contact clearance		1 000 V AC type of clearance: micro-disconnection
Contact - coil distance		
• clearance		≥ 8 mm
• creepage		≥ 8 mm

General data

Operating / release time (typical values)		15 ms / 8 ms
Electrical life	• resistive AC1	> 3 x 10 ⁴ AC coils, 16 A, 250 V AC, ON for 5 s / OFF for 5 s
(number of cycles)		> 10 ⁴ DC coils, 16 A, 250 V AC, ON for 5 s / OFF for 5 s
		> 3 x 10 ⁴ 16 A, 250 V AC, 70 °C, ON for 1 s / OFF for 9 s
Mechanical life (cycles)		> 10 ⁶ AC coils
		> 5 x 10 ⁶ DC coils
Dimensions (L x W x H)		29 x 13 x 25,5 mm
Weight		16 g
Ambient temperature	• storage	-40...+70 °C
(non-condensation and/or icing)	• operating	-40...+70 °C
Cover protection category		IP 40 EN 60529
Environmental protection		RTII EN 61810-7
Relative humidity		5...85%
Shock resistance		10 g
Vibration resistance	(NO/NC)	10 g / 5 g length direction: 10 g / 2 g 10...150 Hz
Solder bath temperature		max. 270 °C
Soldering time		max. 5 s

The data in bold type relate to the standard versions of the relays. The data don't include the power of electronic indicating circuit when the relay picks-up. Operating temperature for relays mounted in sockets on 35 mm rail mount: -40...+55 °C. The distance between the relays mounted side by side: min. 5 mm for versions AC; min. 1,5 mm for versions DC.

RMP85

miniature relays

Dimensions

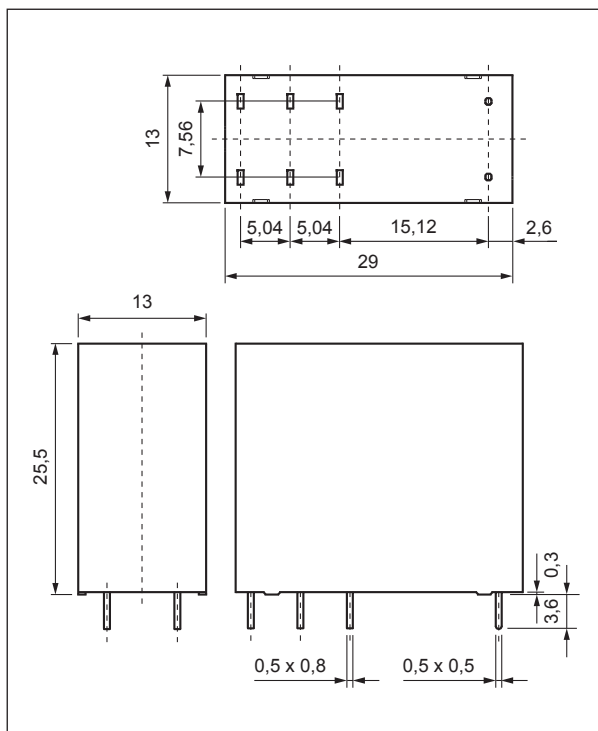

Test buttons type T

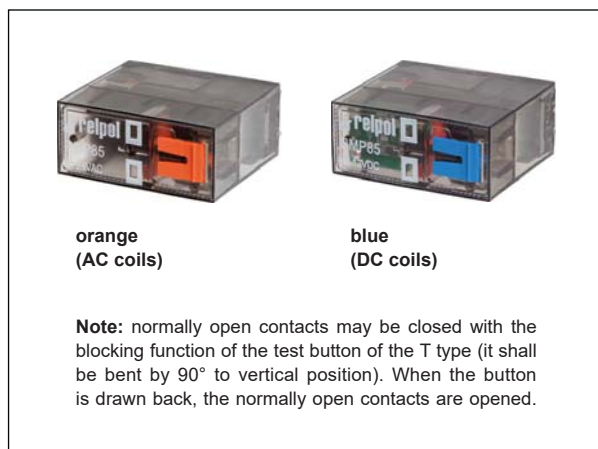

Connection diagram (pin side view)

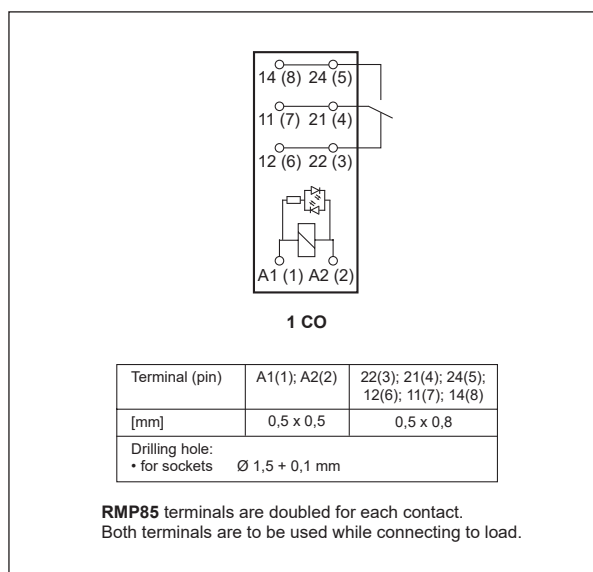

Connection of GZ.80 sockets

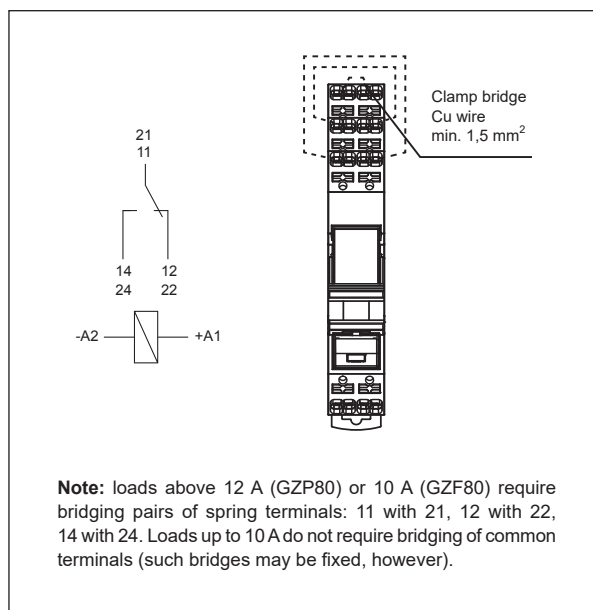

RMP85

miniature relays

Electrical life at AC resistive load.
Switching frequency: 360 cycles/hour

Fig. 1

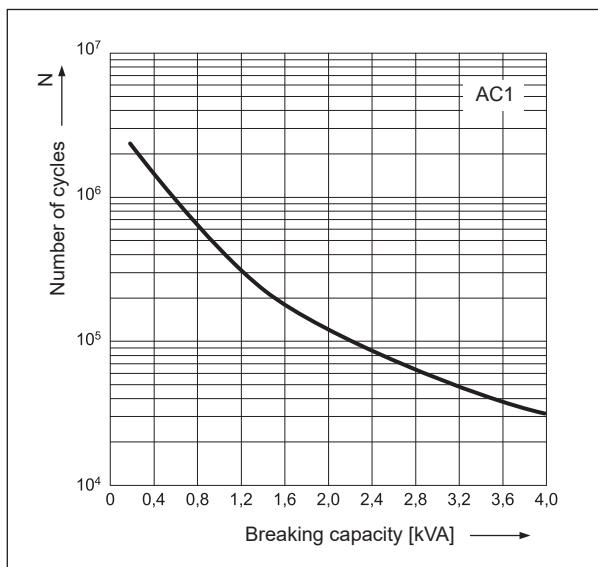

Max. AC 50 Hz resistive load breaking capacity

Fig. 2

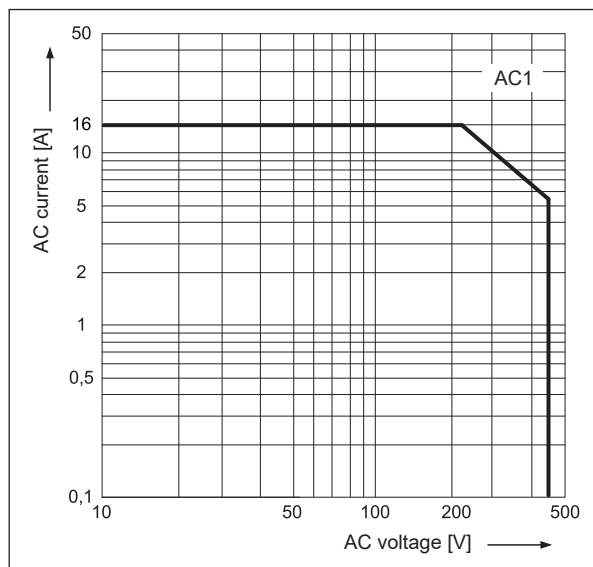

Mounting, sockets and accessories for relays

Relays **RMP85** ④ are designed for mounting in plug-in sockets.

Sockets for RMP85	Accessories			Additional equipment
	Retainer / retractor clips	Spring wire clips	Description plates	
Screw terminals sockets , 35 mm rail mount (acc. to EN 60715) or on panel mounting (one M3 screw)				
GZF80 ④	–	GZ80-1001	–	–
Push-in terminals sockets , 35 mm rail mount (acc. to EN 60715) or on panel mounting (one M3 screw)				
GZP80 ④ ⑤	GZP80-0400	GZ80-1001	MP15	M... ⑥, ZGZP80-8, ZGZP80-2, ZGZP-2 ⑦
Sockets for PCB				
EC 50	–	MH25-2	–	–
GD50	–	MH25-2	–	–

④ The distance between the relays mounted side by side: min. 5 mm for versions AC; min. 1,5 mm for versions DC. ④ Sockets GZ.80: load connection - see page 2. ⑤ Sockets GZP80: wire connection - see page 5. ⑥ Signalling / protecting modules type M... - see page 7. ⑦ Interconnection strips ZGZP... - see page 8.

GZP80

Push-in terminals plug-in sockets for RM84, RM85..., RM87L, RM87P, RMP84, RMP85 - see page 7

NEW



RMP85

miniature relays

Coil data - DC voltage version

Table 1

Coil code	Rated voltage V DC	Coil resistance at 23 °C Ω	Acceptable resistance	Coil operating range V DC ⑧	
				min. (0...+70 °C)	max. (0...+70 °C)
1012	12	360	± 10%	8,4	18,0
1024	24	1 440	± 10%	16,8	36,0
1048	48	5 760	± 15%	33,6	72,0
1110	110	25 200	± 15%	77,0	165,0

The data in bold type relate to the standard versions of the relays. ⑧ The max. allowable voltage is coil overdrive voltage, it is the instantaneous max. voltage which the relay coil could endure in very short time. Relays with 48 V DC and 110 V DC coils shall be absolutely protected against any possibility of operation at voltages higher than the rated voltage.

Coil data - AC 50 Hz voltage version

Table 2

Coil code	Rated voltage V AC	Coil resistance at 23 °C Ω	Acceptable resistance	Coil operating range V AC 50 Hz	
				min. (0...+70 °C)	max. (0...+70 °C)
5024	24	350	± 10%	18,0	26,4
5115	115	8 100	± 15%	86,3	126,5
5230	230	32 500	± 15%	172,5	253,0

The data in bold type relate to the standard versions of the relays.

Ordering codes

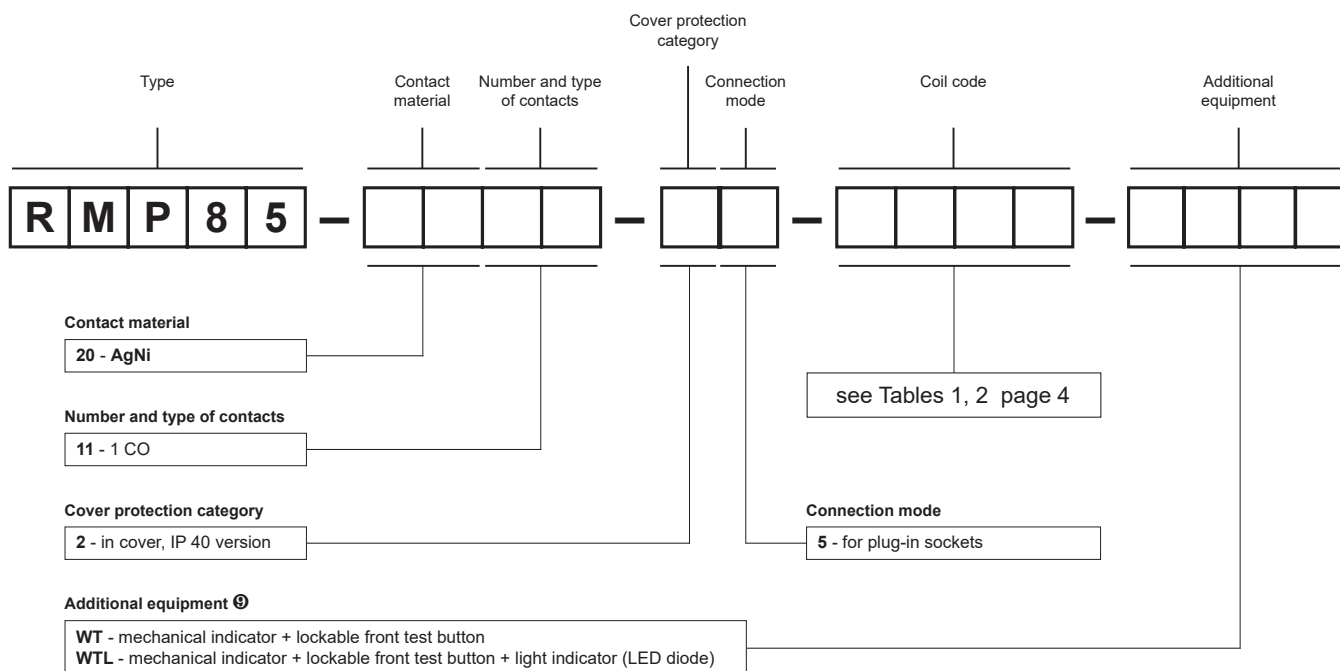

⑨ WT - standard equipment of relays. Test buttons type T - see page 2.

Examples of ordering code:

RMP85-2011-25-1024-WT

relay **RMP85**, for plug-in sockets, one changeover contact, contact material AgNi, coil voltage 24 V DC, with mechanical indicator and lockable front test button, in cover IP 40

RMP85-2011-25-5230-WTL

relay **RMP85**, for plug-in sockets, one changeover contact, contact material AgNi, coil voltage 230 V AC 50 Hz, with mechanical indicator and lockable front test button and light indicator (LED diode), in cover IP 40

Sockets and accessories

GZP80

For RM84, RM85,
RM85 inrush,
RM85 105 °C sensitive,
RM87L, RM87L sensitive,
RM87P, RM87P sensitive,
RMP84, RMP85

Push-in terminals
Max. cross section of the cables:
2 x 1,5 mm² (ferrules without
insulation)
2 x 1 mm² (ferrules with insulation)
Stripping length: 8...10 mm

35 mm rail mount
acc. to EN 60715
or on panel mounting
97 x 15,9 x 45,9(75,8) mm
5 mm pinout
One pole
12 A, 300 V AC
Two poles
8 A, 300 V AC



Connection diagrams ③

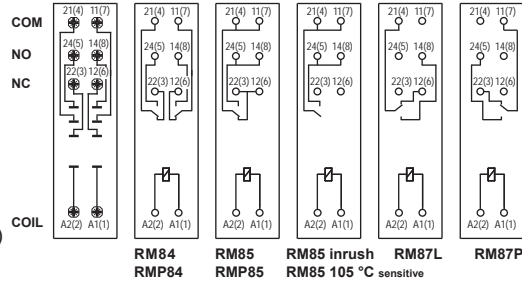

Dimensions

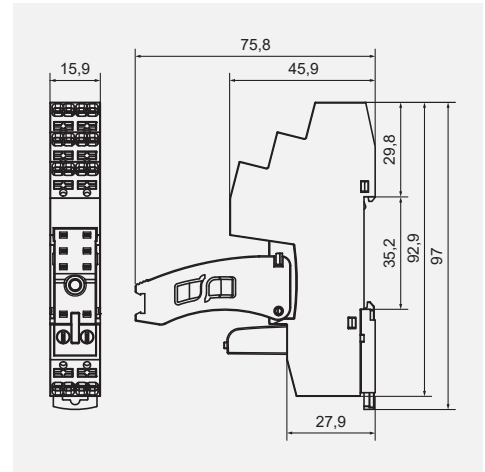

The drawings present inserting wire into the Push-in terminal and removing wire using the button releasing a clamp (assembly without tools).

Accessories ①

Wire connection

GZF80

For RM84, RM85,
RM85 inrush,
RM85 105 °C sensitive,
RM87L, RM87L sensitive,
RM87P, RM87P sensitive,
RMP84, RMP85

Screw terminals
Max. tightening moment
for the terminal: 0,5 Nm
35 mm rail mount
acc. to EN 60715
or on panel mounting
67,2 x 15,5 x 36,5 mm
Two poles, 5 mm pinout
10 A, 250 V AC



Connection diagrams ③

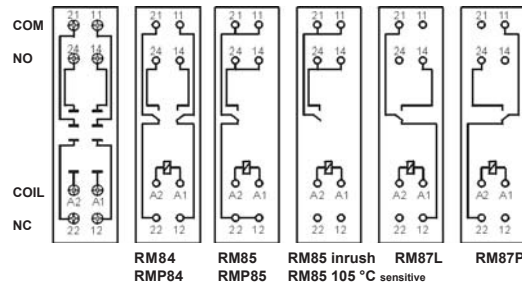

Dimensions

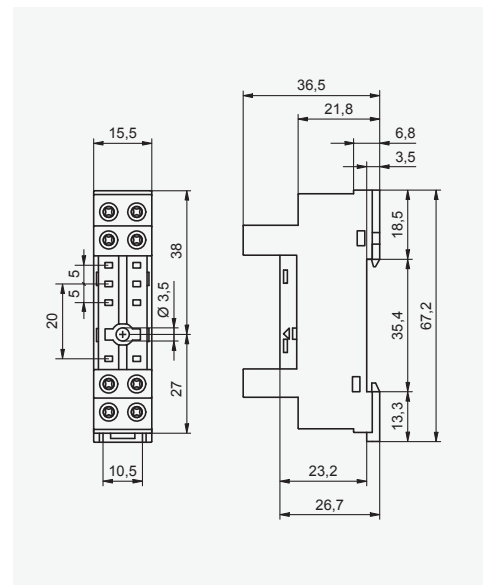

Accessories



① Signalling / protecting modules type M... - see page 7. ② In the bracket the height of socket with retainer / retractor clip is shown. ③ For RM85..., RMP85: loads above 12 A (GZT80, GZM80, GZP80) or 10 A (GZS80, GZF80) require bridging pairs of terminals: 11 with 21, 12 with 22, 14 with 24 - see www.repol.com.pl

Sockets and accessories

GZF80

For RM84, RM85, RM85 inrush, RM85 105 °C sensitive, RM87L, RM87L sensitive, RM87P, RM87P sensitive, RMP84, RMP85

Screw terminals
Max. tightening moment for the terminal: 0,5 Nm
35 mm rail mount acc. to EN 60715 or on panel mounting
67,2 x 15,5 x 36,5 mm
Two poles, 5 mm pinout
10 A, 250 V AC



Connection diagrams

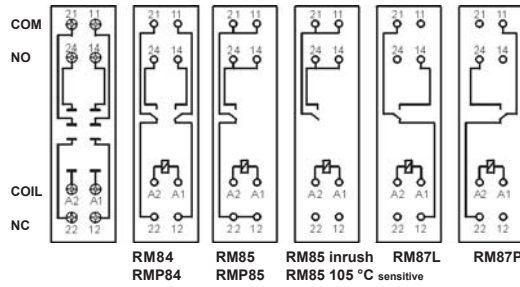

Dimensions

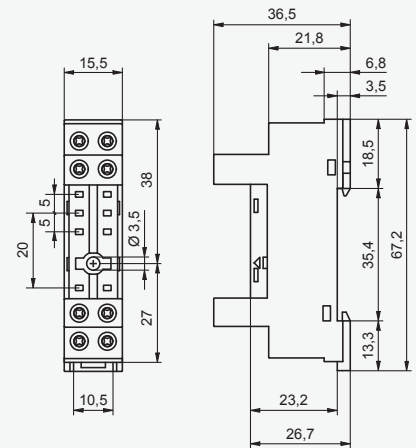

Accessories



EC 50

For RM84, RM85, RM85 inrush, RM85 105 °C sensitive, RM87L, RM87L sensitive, RM87P, RM87P sensitive, RM83, RMP84, RMP85

For PCB
31,3 x 12,7 x 9 mm
Two poles, 5 mm pinout
12 A, 250 V AC



Pinout

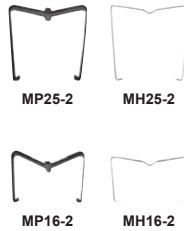
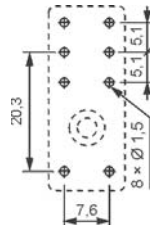

Dimensions

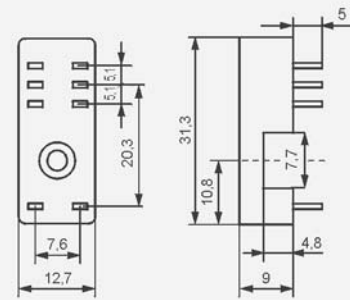

Accessories

GD50

For RM84, RM85, RM85 inrush, RM85 105 °C sensitive, RM87L, RM87L sensitive, RM87P, RM87P sensitive, RM83, RMP84, RMP85

For PCB
31,5 x 13 x 9 mm
Two poles, 5 mm pinout
8 A, 300 V AC



Pinout

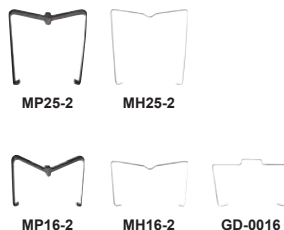
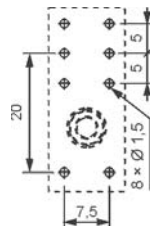

Dimensions

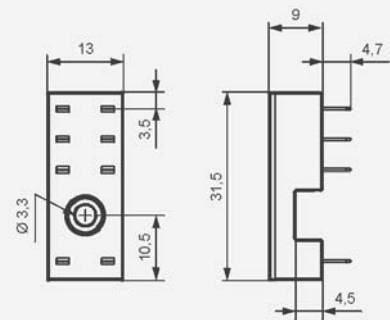

⊕ For RM85..., RMP85: loads above 12 A (GZT80, GZM80, GZP80) or 10 A (GZS80, GZF80) require bridging pairs of terminals: 11 with 21, 12 with 22, 14 with 24 - see www.repol.com.pl

Signalling / protecting modules type M...

For sockets type:

GZT80, GZM80, GZS80, GZP80, GZT92, GZM92, GZS92, ES 32, GZT2, GZM2, GZT3, GZM3, GZT4, GZM4, GZP4

Modules type M... are parallelly connected with relay coil.

Polarization P: -A1/+A2. Polarization N: +A1/-A2.



Modules type M...	Layout	Voltage	Type of module ① ②
Module D (polarization P) It limits overvoltage on DC coils.		6/230 V DC	M21P
Module D (polarization N) It limits overvoltage on DC coils.		6/230 V DC	M21N
Module LD (polarization P) It limits overvoltage on DC coils. Coil energizing indication.		6/24 V DC 24/60 V DC 110/230 V DC	M31R, M31G M32R, M32G M33R, M33G
Module LD (polarization N) It limits overvoltage on DC coils. Coil energizing indication.		6/24 V DC 24/60 V DC 110/230 V DC	M41R, M41G M42R, M42G M43R, M43G
Module RC It protects against EMC disturbance. It limits overvoltage.		6/24 V AC/DC 24/60 V AC/DC 110/240 V AC/DC	M51 M52 M53
Module L Coil energizing indication.		6/24 V AC/DC 24/60 V AC/DC 110/240 V AC/DC	M61R, M61G M62R, M62G M63R, M63G
Module LV It limits overvoltage on AC and DC coils. Coil energizing indication.		6/24 V AC/DC 24/60 V AC/DC 110/240 V AC/DC	M91R, M91G M92R, M92G M93R, M93G
Module V It limits overvoltage on AC coils. No indication.		6/24 V AC 110/130 V AC 220/240 V AC	M71 M72 M73
Module R It limits harmful voltage on AC coils induced in long lines which causes unwanted making of the relay.		110/240 V AC	M103

① M...R - LED red, M...G - LED green

② When ordering modules indicate their color: gray or black.

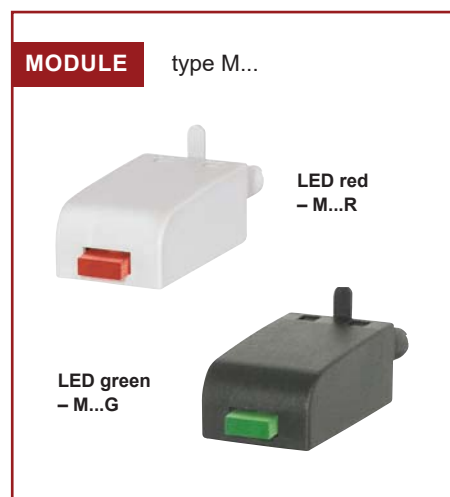

Interconnection strips ZGZP...

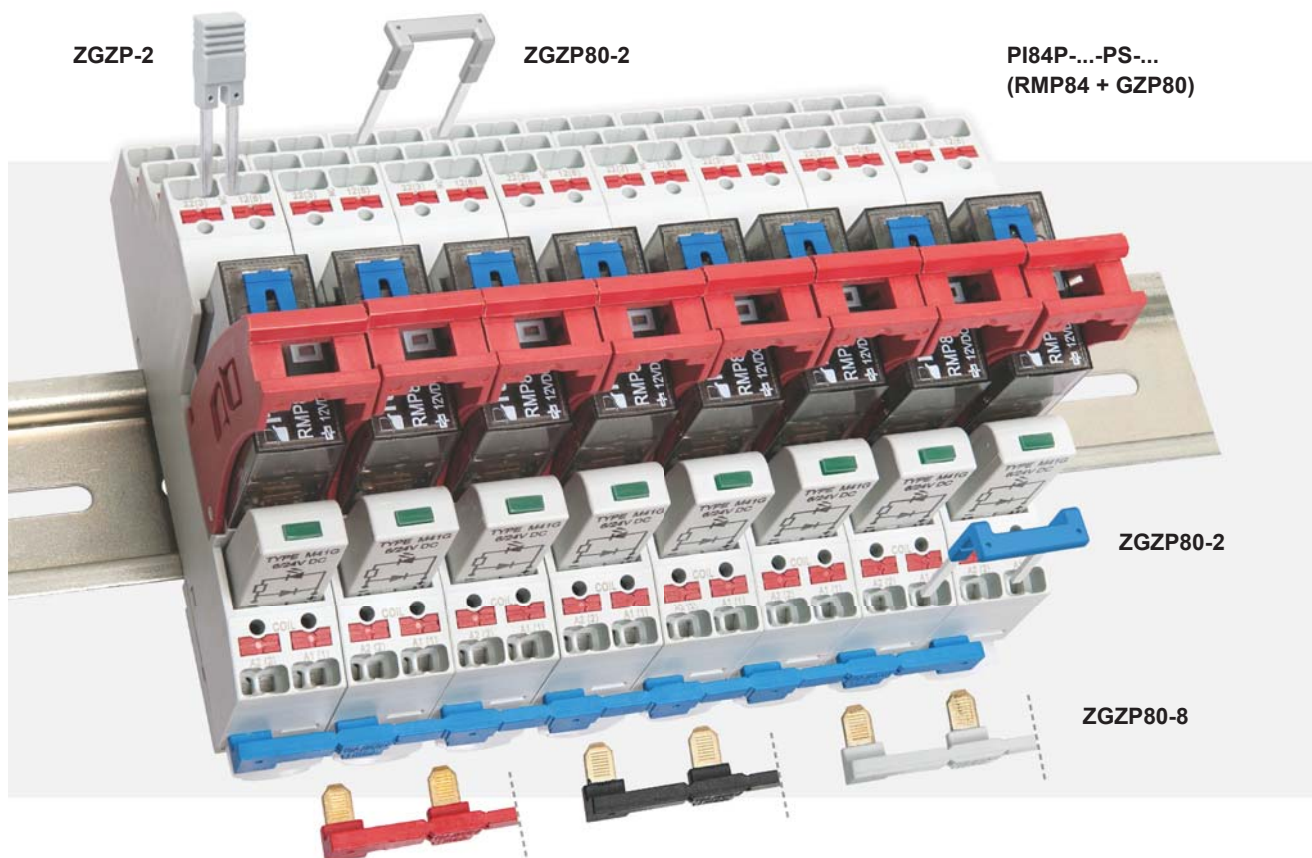

■ ZGZP... for:

Plug-in sockets	Relays for plug-in sockets	Interface relays ③
GZP80	RM84, RM85, RM85 inrush, RM85 105 °C sensitive, RM87L ④, RM87P ④, RMP84, RMP85	PI84-...-PS-... (RM84 + GZP80) PI85-...-PS-... (RM85 + GZP80) PI84P-...-PS-... (RMP84 + GZP80) PI85P-...-PS-... (RMP85 + GZP80)

③ Interface relay **PI84** (**PI85**, **PI84P**, **PI85P**) is offered as a **set**: electromagnetic relay **RM84** (**RM85**, **RMP84**, **RMP85**) + plug-in socket **GZP80** + signalling / protecting module type **M...** + retainer / retractor clip **GZP80-0400**.

④ Also versions RM87. sensitive

■ Interconnection strips ZGZP...

- designed for the co-operation with plug-in sockets of miniature relays and with interface relays PI84, PI85, PI84P, PI85P, which are equipped with Push-in terminals; sockets and relays are mounted on 35 mm rail mount acc. to EN 60715,
- strip **ZGZP80-8** bridges common input signals (coil terminals A1 or A2), maximum permissible current is 10 A / 250 V AC, possibility of connection of 8 sockets or relays,



ZGZP80-8 GY grey



ZGZP80-8 BK black



ZGZP80-8 RD red



ZGZP80-8 BE blue

- strip **ZGZP80-2** bridges common input signals (coil terminals A1 or A2) or output signals, possibility of connection of 2+n sockets or relays,



ZGZP80-2 GY grey



ZGZP80-2 BK black



ZGZP80-2 RD red



ZGZP80-2 BE blue

- jumper **ZGZP-2** bridges the neighboring poles of single socket **GZP80**.



ZGZP-2 GY grey



ZGZP-2 BK black



ZGZP-2 RD red



ZGZP-2 BE blue